

# Datatech+

Precision air conditioners with inverter driven brushless DC compressor for technological environments

---

---



## General

Datatech+ represents the state of the art as regards efficient, precise and reliable cooling of Data Processing Centres, small and medium-sized computer rooms, laboratories and technological environments in general.

The combination of inverter-controlled brushless DC compressors, EC electronic switching fans and electronic thermostatic valves together with a sophisticated control algorithm allows the highest performance to be achieved as required for the air conditioning of technological equipment.

## Quick facts

- ▶ High sensible heat removal rate.
- ▶ Exceptional efficiency at partial loads, that is, the required refrigeration capacity is lower than the nominal design value.
- ▶ Quick response to changes in heat load, with the possibility of changing the frequency of rotation of the compressor between 30 and 120% of the rated value.
- ▶ Constancy and precision of control of thermo-hygrometric variables.

Datatech+ is offered in several versions and set-ups, together with a large range of accessories and options, to give everything necessary to be THE solution to every precision air conditioning problem.

## Index

configurations	3
technical features	6
technical data ED	10
electrical data ED	14
technical data ED-DC	12
electrical data ED-DC	14
technical data EDW-FC	13
electrical data EDW-FC	15
operating limits	16
dimensional drawing	18

## CONFIGURATIONS

Datatech+	O	ED	A	23.1	CO	--
1	2	3	4	5	6	7

1. **Series**
2. **Air delivery direction**  
O = OVER upwards  
U = UNDER downwards
3. **Tipo di unit**  
ED = direct expansion with condensation
4. **Type of condenser**  
A = remote air  
W = incorporated water
5. **Approximate capacity**
6. **Version**  
CO = cooling  
CH = cooling + heating  
HH = cooling + heating + humidification + dehumidification
7. **Set-ups**  
DC = Dual Cooling  
FC = Free Cooling  
-- = None

## EXAMPLE OF UNIT NOMENCLATURE

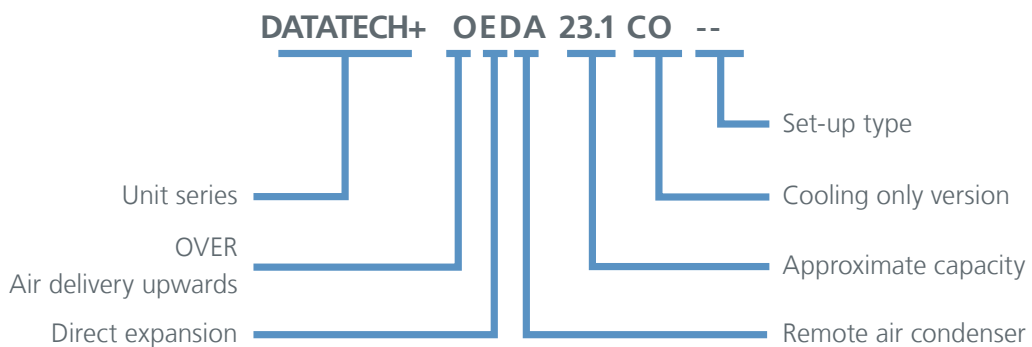

## BRUSHLESS DC

The brushless DC motor is inherently more efficient than an AC motor and is designed to be speed modulated.



BRUSHLESS DC COMPRESSOR

## TEMPERATURE TREND

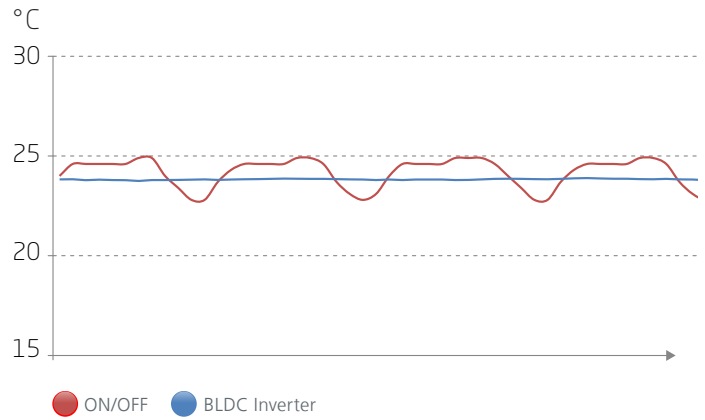

## NET EFFICIENCY

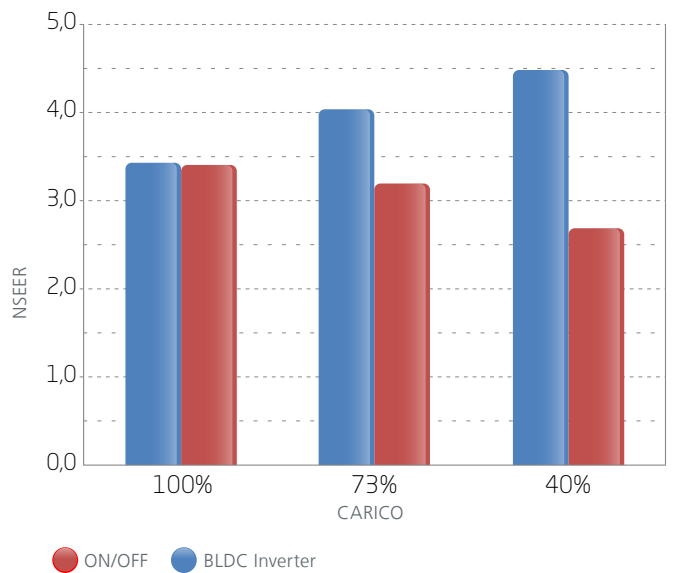

The compressor can modulate between 30% and 130% of its nominal speed.

## EC FANS

EC fans are highly efficient, maintenance-free and have an easy AUTOMATIC speed control.

The fan modulates together with the compressor to have greater efficiency and control flexibility.



EC FANS

## ELECTRONIC THERMOSTATIC VALVE

Necessary for integrated and optimal control of the variable capacity.

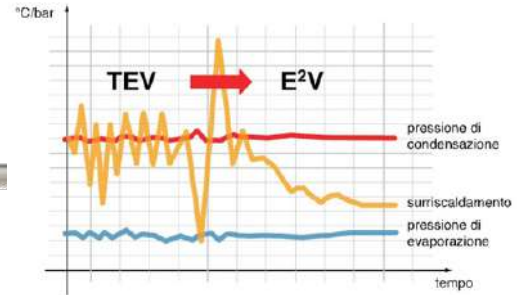

## REDUNDANCY APPLICATIONS

### CLASSIC RUNNING/STANDBY

primary with secondary unit used only as a backup

#### EER 3\*

A-main unit

B-backup unit

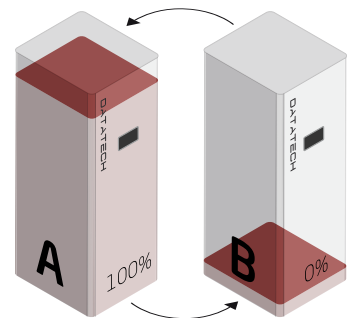

### SMART DUET

Both units used at partial load

#### EER 4\*

A-main unit

B-main unit

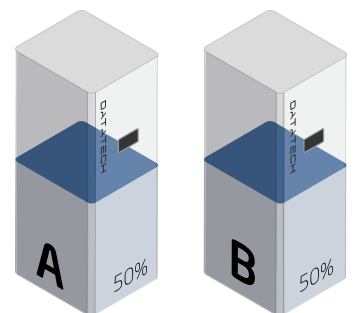

● ON/OFF ● BLDC Inverter

\*thermal load 23 kW at 24°C/50% rh internal conditions and 35° outdoor conditions

## BODY

For the best thermal and acoustic insulation, the cabinet is made with galvanized steel sandwich panels that are externally epoxy polyester powder coated, RAL 7016 (anthracite grey) with textured finish. The panels are internally insulated with glass wool, to obtain fire insulation class A1 (in accordance with EN13501). Air tightness is achieved with adhesive sealing strips placed all around the edges of the panels. The uprights and infills are made of galvanized sheet-iron.

The front of the panel closing the electrical control panel can be opened by handle for easy inspection of the inside. Access to all the refrigerant and electrical components of the unit is from the front of the machine only; this solution makes it unnecessary to carry out any work from the side and eliminates the obligation to consider "technical spaces" around the air conditioning units. All the front panels are fixed to the body by ¼ turn fasteners and can therefore be easily removed.

All the materials forming the body are recyclable and CFC-free.

## FANS

The units are fitted with radial fans with backward-curved blades, with high efficiency EC electronic switching electric motor. The speed of rotation of the fan is continuously variable and entirely managed by the microprocessor control to guarantee the best efficiency and the best thermodynamic balance of the refrigerant circuit at all times. The self-adjusting nature of the electronic control of the fans allows the correct air flow rate to be ensured at all times.

The flow of air into the fan is continuously controlled by a differential pressure switch that activates an alarm when there is no air flow.

The motors are provided with integrated electronic protection against overtemperature, overcurrent, over or under-voltage with absence of one or more phases.

## FILTERS

The filters are pleated and in a rigid galvanized steel frame, of filtration class ISO Coarse 75% (ISO 16890-3; G4 - EN779) and designed to minimize load losses and to have a high degree of filtration. The thickness of the filters can be 50 or 100 mm depending on the sizes or the set-ups. The filters are always removed from the front of the unit. High efficiency filters ISO ePM10 (M5), ISO ePM10 75% (M6), ISO ePM1 50% (F7) with low load loss can be supplied on request.

## COMPRESSORS

The compressors are "twin rotary" or "scroll" with inverter-controlled brushless DC motor, operating with R410A and power supply of 400-460V/3ph/50-60Hz. The compressors are provided with integrated thermal overload protection and acoustic hood.

The compressor motor control driver is provided with integral electronic protection against overtemperature, overcurrent, over or under-voltage with absence of one or more phases.

The electronic control of the inverter is provided with automatic soft-start system and continuous control of the compressor curve to prevent and correct its use beyond the maximum allowed limits.

## REFRIGERANT CIRCUIT

The refrigerant circuit comprises:

- Liquid receiver (for versions with remote condenser)
- Delivery oil separator (for versions with remote condenser)
- Electronically-controlled thermostatic expansion valve
- Solenoid valve for shutting off the refrigerant liquid
- Refrigerant liquid flow indicator
- Solid cartridge freon filter
- Safety valve
- High pressure safety pressure switch with manual reset
- Low pressure switch with automatic reset
- Shut-off valves for external connections (versions with remote condenser)
- Copper refrigerant pipes with anti-condensation insulation on the suction line
- Pipe taps on suction and delivery side and charging valve on liquid side.

## EVAPORATOR COILS

The evaporator coils are finned coil, with copper tubes and aluminium fins with hydrophilic surface treatment. The fin profile is specially designed to prevent carry-over of condensation even at high through speeds. The coils are optimized for use with refrigerant R410A.

A stainless steel condensate collection basin is installed at the base of the coil, complete with fitting for drain and siphon.

## CONDENSER

### Unit with "EDA" remote condenser

For air cooled units, remote condensers with axial fans are envisioned. Remote condensers are supplied as accessory, and they always have to be powered with 230V/1~/50. They are available as: standard, low noise, oversized, oversized low noise and High Temperature (HT). Their fan motors can be AC or, as accessory, EC brushless type (not for HT). Protections and speed regulation for remote condensers are located inside the indoor unit (except some HT models).

The speed controller allows correct condensation with external ambient temperatures down to -15°C. For beyond that limit, and down to -25°C, a low temperature kit is available with flooding condensation control.

### Unit with "EDW" water condenser

For units with water condensation, the condensers are braze-welded stainless steel (AISI 316) plate condensers, installed as standard inside the unit.

### WATER COILS (unit with additional water cooling coil)

The coils are finned coil, with copper tubes and aluminium fins with hydrophilic surface treatment. The fin profile is specially designed to prevent carry-over of condensation even at high through speeds.

A stainless steel condensate collection basin is installed at the base of the coil, complete with fitting for drain and siphon.

### HYDRAULIC CIRCUIT (unit with additional water cooling coil)

This comprises a 3-way modulating valve with 0-10V servo control that controls environmental conditions by metering the flow of water running through the exchange coil. The "Dual Cooling" units are provided with water flow switch and temperature probe for checking that water is flowing and its temperature. The "Free Cooling" units are provided with incoming water temperature probe.

## ELECTRICAL CONTROL PANEL

The panel comprises:

- Main power switch
- Automatic circuit breakers and fuses to protect the power and auxiliary circuits
- Contactors for heaters and humidifier
- Microprocessor to control the following functions:
  - Ambient temperature
  - Humidity (HH versions)
  - Speed of the delivery fans
  - Speed of the condensation fans
  - Timing of compressors with automatic rotation

- Alarm signal on two levels
- Controlled automatic reset of high and low pressure alarms
- Alarm log recording
- Management of several units in local network with automatic rotation and distributed control
- Connection via serial line to supervision system.

- Display of the following on the display:
  - Ambient temperature
  - Humidity (HH versions)
  - Air flow rate
  - Saturated suction and delivery pressure and temperature (virtual pressure gauge function)
  - Description of alarms
  - Operating hour meter
  - Status of controlled devices.

Power supply [V/ph/Hz]: 400/3~/50 ±5%.

400/3~/50 ±5% +N if it the remote condenser is present.

## CONTROLS AND SAFETY DEVICES

- Electro-mechanical high pressure safety pressure switch with manual reset
- High and low pressure transducer
- Low pressure switch with controlled automatic reset
- High pressure safety valve
- Integral electronic protection of the fan and compressor motor.

## TESTING

Tests carried out at the factory:

- Leak tightness of the refrigerant circuit
- Functionality of the electrical control panel and the control system
- Correct intervention of the safety devices
- Operation of fan and heaters
- Operation of the compressor in versions with incorporated water condenser.

The units are delivered:

Unit with "EDA" remote condenser

- with refrigerant circuit charged with nitrogen, oil charge in the compressor and in the separator.

Unit with "EDW" water condenser

- complete with oil and refrigerant.

## ELECTRIC POST-HEATING

The CH and HH versions are supplied with electric post-heating consisting of a bank of electric heaters, with heating elements with low surface temperature, made of AISI stainless steel.

In the event of overheating, a safety thermostat intervenes by stopping the power supply to the heaters and activating an alarm.

As an alternative to electric heaters, it is possible to have a hot water coil with three-way valve or a hot gas post-heating coil, to minimize energy consumption.

## HUMIDIFICATION (HH version)

Immersed electrode humidifier supplied with mains water, controlled through microprocessor, for steam production with continuous modulation.

## SET-UPS

### DATATECH DC: Dual Cooling unit

Units with Dual Cooling set-up have two coils; one is a direct expansion coil connected to the compressor, with backup function; the other is a chilled water coil, as a rule connected to an external water chiller, with primary cooling function. A flow switch and a temperature probe placed at the coil inlet determine when operation must be passed to the direct expansion coil. The conditions that cause the direct expansion coil (and therefore the compressor) to start are the following:

- no chilled water flow
- temperature of chilled water above a certain settable value
- room heat load not met by the water coil alone. The direct expansion coil is, in this case, used additionally.

Compared to the \*ED\* unit with basic set-up, the following additional components are present:

- chilled water coil
- three-way modulating valve via electrical signal 0 - 10 Vdc
- paddle flow switch
- NTC temperature probe for incoming water
- NTC temperature probe for outgoing air.

### DATATECH FC: Free Cooling unit

Free Cooling units should be combined with a drycooler that uses outside air to cool for free the glycol water mixture that is circulated in a closed circuit so enabling energy savings to be maximized. They have two coils: one is a water coil (upstream of the air flow) and the other is a direct expansion coil. The free-cooling water coil is placed in series with the plate condenser and with the drycooler. A three-way valve allows the

water flow to pass or not pass through the free cooling coil. The microprocessor control measures the water temperature, by means of a probe located at the coil inlet, and, if this is lower than the return air temperature, it makes the mixture go first through the free cooling coil and then through the condenser and drycooler. The compressor and the direct expansion coil will operate additionally during periods when free cooling alone is unable to meet the whole heat load, and exclusively when conditions for free cooling are not present.

The unit is inclusive of a condensation control valve on the water side supplied with it.

## ACCESSORIES

### AEREAULIC CIRCUIT ACCESSORIES

- Dirty filter alarm

The flow of air into the fan is continuously controlled by a differential pressure switch that activates an alarm when there is no air flow.



- High efficiency filters with filter grade ISO ePM10 50% (M5) – ISO ePM10 75% (M6) – ISO ePM1 50% (F7)

As an alternative to the standard ISO Coarse 75% (G4) filter, filters with higher efficiency and low load loss are available, and these are completely interchangeable even at a later date.



- Return and delivery plenum

Metal structure with sandwich panelling, in the same finish and of the same type as the air conditioners, for air delivery upwards in the OVER versions with vertical flow, or for air return from above for the UNDER versions.

- Room delivery plenum with grille

Metal structure with sandwich panelling, in the same finish and of the same type as the air conditioners, complete with front grille for room air distribution for the OVER versions.



- Base frame with height-adjustable feet

For installations on raised modular floor; consisting of black painted steel tubular section complete with height-adjustable anti-vibration feet ( $\pm 25\text{mm}$ ).

Available in various heights, with or without deflector for channelling the delivery air.

- Motor-driven non-return shutters for air

These are positioned above the units, and can also be installed at a later date. During a machine stop, the shutters close to prevent recirculation of air through the units whose fan is not running (for units with under-floor air delivery or channelled into a common plenum).

#### HYDRAULIC CIRCUIT ACCESSORIES

- Post-heating with hot water coil

This consists of a coil made with copper tubes and aluminium fins provided with pre-assembled 3-way on/off valve.

- 2-way pressure switch valve

To regulate the condensation pressure in units condensed with total loss water, with consequent optimization of water consumption, and to prevent it from being wasted with refrigerant circuit not running.

#### ELECTRICAL ACCESSORIES

- Probe for humidity indication

This is available for CO-CH units and enables display of ambient humidity and dehumidification in the CH versions.

- Serial cards for supervision and teleservice

The unit can be connected to supervision and teleservice systems by installation of a serial card.

Depending on the required communication protocol, various options are available:

- RS485 serial card allows communication with Carel or Modbus protocol.
- Serial card for communication with LonWorks® networks (FTT10 interface).
- Card for connection to BACnet™ networks such as RS485 MS/TP.
- RS232 serial card that allows the control to be connected to a modem for standard telephone connections
- PSTN, and for GSM to send SMS messages.
- pCO Web card for connection to Ethernet networks with SNMP protocol, http, BACnet™ over IP.



Serial card RS485 PCOS004850



Serial card PCO100MDM0



Serial card LonWorks® PCO1000F0



Serial card pCO Web PCO1000WB0



Serial card BacNet™

- Provision for remote condenser

This accessory is mandatory if the unit is combined with the remote condenser supplied by us.

The provision consists of an automatic circuit breaker and the speed regulation for fans of remote condenser. The speed regulation is realized through a phase cutting speed controller (condenser with AC fans), or directly by modulating signal coming from the electronic board of indoor unit. These components are always placed inside the indoor unit.

#### OTHER ACCESSORIES

- Fire sensors

For fire detection with sensors placed on the unit. The sensor is a thermo-differential sensor and can perceive the speed with which the temperature is rising so as to react quickly to the currents of hot air from a fire. It can protect an area of 49 m<sup>2</sup> (7x7).

- Smoke sensors

For smoke detection with sensors placed on the unit. The sensor is an optical sensor and is approved at national level by the Interior Ministry while at international level it has been type-approved in conformity with harmonized European regulations CEN EN 54 part 7 and 8. It can protect an area of 81 m<sup>2</sup> (9x9).

- Under-floor flooding sensor

For detection of water leaks, complete with sensor to be placed in the area to control. Further sensors can be connected on request to allow control of several areas.

- Stainless steel unit containment tank

This is positioned under the unit (typically under the base frame) and collects any water leaks and, combined with the flood sensor, allows containment and prompt warning of these leaks.

## TECHNICAL DATA - DATATECH+ ED

Unit size			7.1m	7.1t	12.1	16.1	23.1	27.1	33.1	35.2
<b>Cooling</b>										
Total cooling capacity	(1)	kW	6,9	6,9	11,9	17,2	21,5	27,0	34,6	36,1
Sensible cooling capacity	(1)	kW	6,7	6,7	11,7	15,0	20,5	25,0	31,0	35,0
SHR			0,97	0,97	0,98	0,87	0,95	0,93	0,90	0,97
EER	(1),(2)		3,8	3,8	3,6	3,6	3,7	3,6	3,6	3,7
<b>Compressors</b>										
Number		n°	1	1	1	1	1	1	1	2
Power input	(1)	kW	1,7	1,7	2,9	4,3	5,4	6,8	8,5	8,9
<b>Fans</b>										
Number		n°	1	1	1	1	1	1	1	2
Nominal air capacity		m³/h	2000	2000	4000	4160	6500	7650	8000	11500
Fan power input - UNDER version	(2)	kW	0,2	0,2	0,4	0,5	0,5	0,8	1,2	0,8
Fan power input - OVER version	(2)	kW	0,2	0,2	0,4	0,5	0,5	0,8	1,2	0,8
Maximum available static pressure - Downflow units	(5)	Pa	350	350	345	265	520	410	280	550
Maximum available static pressure - Upflow units	(5)	Pa	350	350	345	265	520	410	280	550
<b>Refrigerant connections (EDA units)</b>										
Gas discharge		n°x mm	1 x 10	1 x 10	1 x 12	1 x 16	1 x 16	1 x 18	1 x 18	1 x 18
Liquid		n°x mm	1 x 10	1 x 10	1 x 12	1 x 16	1 x 16	1 x 16	1 x 18	1 x 18
<b>Plate condenser (EDW unit)</b>										
Number		n°	1	1	1	1	1	1	1	1
In/out connections			G1"	G1"	G1"	G1"	G1"	G1 1/4"	G1 1/4"	G1 1/4"
Pressure drop		kPa	31	31	31	33	36	36	35	35
<b>Electric heating (CH-HH version)</b>										
Potential		kW	3	3	4,5	4,5	4,5	9	9	9
Operation stages		n°	1	1	1	1	1	2	2	2
<b>Hot water coil (CH-HH version)</b>										
Potential	(3)	kW	6,2	6,2	10,6	10,7	24	26,4	27	41,7
Total pressure drop		kPa	25	25	12	13	29	35	36	25
<b>Humidifier (HH version)</b>										
Potential		kg/h	1,5	1,5	3	3	5	5	5	5
<b>Sound pressure levels</b>										
Sound pressure levels - UNDER	(4)	dB(A)	49,1	49,1	52,4	53,0	53,9	57,9	58,2	59,9
Sound pressure levels - OVER	(4)	dB(A)	50,3	50,3	53,7	54,9	55,5	59,4	58,9	60,0
<b>Matching with remote condensers (EDA units)</b>										
Number		n°	1	1	1	1	1	1	1	1
Model			NHNM 1135.5	NHNM 1135.5	NHNM 1145.2	NHNM 1145.4	NHNM 1245.2	NHNM 1245.3	NHNM 2335.3	NHNM 2335.3
Low noise model			NHLM 1145.2	NHLM 1145.2	NHLM 1145.4	NHLM 1245.2	NHLM 1245.3	NHLM 1250.5	NHLM 2245.2	NHLM 2245.2
Oversized model			NHNM 1145.2	NHNM 1145.2	NHNM 1145.3	NHNM 1245.2	NHNM 1245.3	NHNM 1245.4	NHNM 2245.2	NHNM 2245.2
Oversized low noise model			NHLM 1145.2	NHLM 1145.2	NHLM 1150.4	NHLM 1245.3	NHLM 1250.5	NHLM 2245.2	NHLM 2245.3	NHLM 2245.3
HT model			NHNM 1145.4	NHNM 1145.4	NHNM 1245.2	NHNM 2245.2	NHNM 2245.2	NHNM 2245.4	KA4M 2250.4	KA4M 2250.4
<b>Matching with remote drycoolers (EDW units)</b>										
Number		n°	1	1	1	1	1	1	1	1
Model		n°	DGS501AS	DGS501AS	DGS501CS	DGS502BS	DGS502CS	DGS503BS	DGS504BS	DGS504BS
<b>Dimensions and weight of basic unit</b>										
Cabinet size			SXS	SXS	XS	XS	S	S	S	M
Length		mm	607	607	705	705	1100	1100	1100	1750
Depth		mm	500	500	650	650	850	850	850	850
Height		mm	1850	1850	1990	1990	1990	1990	1990	1990
UEDW HH operating weight		kg	182	182	248	280	374	382	400	608
OEDW HH operating weight		kg	182	182	248	280	369	376	394	574

(1) Air inlet 24°C 50%rh. 45°C saturated condensing temperature;

(2) 20Pa available pressure, ISO Coarse 75% (G4) filters;

(3) Inlet air temperature 20 °C water in/out 80/70 °C.;

(4) 2 m front of the unit, air distribution through raised floor (UNDER) or ducted (OVER).;

(5) Static pressure obtainable at reduced air flow

Gross cooling capacities indicated. For net cooling capacities, subtract fan power input..

## TECHNICAL DATA - DATATECH+ ED

Unit size			36.2	45.2	44.2	58.2	66.3	82.3	100.4
<b>Cooling</b>									
Total cooling capacity	(1)	kW	34,3	45,4	44,5	56,7	66,8	81,4	96,6
Sensible cooling capacity	(1)	kW	34,1	43,0	42,6	52,3	63,2	76,1	87,1
SHR			0,99	0,95	0,96	0,92	0,95	0,93	0,90
EER	(1),(2)		3,9	3,7	3,8	3,7	3,8	3,7	3,7
<b>Compressors</b>									
Number		n°	2	2	2	2	3	3	4
Power input	(1)	kW	8,1	11,2	10,6	13,1	15,8	19,4	22,3
<b>Fans</b>									
Number		n°	2	2	2	2	3	3	3
Nominal air capacity		m³/h	11500	13500	13500	14500	20000	23000	23000
Fan power input - UNDER version	(2)	kW	0,76	1,23	1,23	2,06	1,75	2,54	3,86
Fan power input - OVER version	(2)	kW	0,76	1,23	1,23	2,06	1,75	2,54	3,86
Maximum available static pressure - Downflow units	(5)	Pa	550	460	460	330	480	385	245
Maximum available static pressure - Upflow units	(5)	Pa	550	460	460	330	480	385	245
<b>Refrigerant connections (EDA units)</b>									
Gas discharge		n°x mm	2 x 16	1 x 18	2 x 16	2 x 16	(1 x 16) + (1 x 18)	(1 x 16) + (1 x 18)	2 x 18
Liquid		n°x mm	2 x 16	1 x 18	2 x 16	2 x 16	(1 x 16) + (1 x 18)	(1 x 16) + (1 x 18)	2 x 18
<b>Plate condenser (EDW unit)</b>									
Number		n°	2	1	2	2	2	2	2
In/out connections			G1"	G1 1/4"	G1"	G1 1/4"	G1 1/4"	G1 1/4"	G1 1/4"
Pressure drop		kPa	35	36	38	37	35	59	35
<b>Electric heating (CH-HH version)</b>									
Potential		kW	9	9	9	9	13,5	13,5	13,5
Operation stages		n°	2	2	2	2	3	3	3
<b>Hot water coil (CH-HH version)</b>									
Potential	(3)	kW	41,7	45,5	45,5	47,2	71,4	77,2	77,2
Total pressure drop		kPa	25	30	30	32	54	62	62
<b>Humidifier (HH version)</b>									
Potential		kg/h	5	5	5	5	8	8	8
<b>Sound pressure levels</b>									
Sound pressure levels - UNDER	(4)	dB(A)	59,9	60,6	60,6	62,0	63,6	64,6	64,8
Sound pressure levels - OVER	(4)	dB(A)	60,0	61,9	61,9	63,5	65,0	66,6	66,8
<b>Matching with remote condensers (EDA units)</b>									
Number		n°	2	1	2	2	2	2	2
Model			NHNM 1145.4	NHNM 2245.2	NHNM 1245.2	NHNM 1245.3	NHNM 1245.2 + NHNM 2245.2	NHNM 1245.3 + NHNM 2245.3	NHNM 2245.2
Low noise model			NHLM 1245.2	NHLM 2245.3	NHLM 1245.3	NHLM 1250.5	NHLM 1245.3 + NHLM 2245.3	NHLM 1245.4 + NHLM 2245.3	NHLM 2245.3
Oversized model			NHNM 1245.2	NHNM 2245.3	NHNM 1245.3	NHNM 1245.4	NHNM 1245.4 + NHNM 2245.3	NHNM 1245.4 + NHNM 2245.4	NHNM 2245.4
Oversized low noise model			NHLM 1245.3	NHLM 2245.4	NHLM 1250.5	NHLM 2245.2	NHLM 1250.5 + NHLM 2245.4	NHLM 2245.2 + NHLM 2245.4	NHLM 2245.4
HT model			NHNM 2245.2	KA4M 2350.2	NHNM 2245.2	NHNM 2245.3	NHNM 2245.2 + KA4M 2250.4	NHNM 2245.3 + KA4M 2350.2	KA4M 2350.2
<b>Matching with remote drycoolers (EDW units)</b>									
Number		n°	1	1	1	1	1	1	1
Model		n°	DGS504BS	DGS504CS	DGS504CS	DGS634CT	DGS634CT	BDMS802DT	BDMS803BT
<b>Dimensions and weight of basic unit</b>									
Cabinet size			M	M	M	M	L	L	L
Length		mm	1750	1750	1750	1750	2650	2650	2650
Depth		mm	850	850	850	850	850	850	850
Height		mm	1990	1990	1990	1990	1990	1990	1990
UEDW HH operating weight		kg	608	616	634	691	953	985	1023
OEDW HH operating weight		kg	638	586	664	721	939	985	1009

(1) Air inlet 24°C 50%rh. 45°C saturated condensing temperature;  
 (2) 20Pa available pressure, ISO Coarse 75% (G4) filters;  
 (3) Inlet air temperature 20 °C water in/out 80/70 °C.;  
 (4) 2 m front of the unit, air distribution through raised floor (UNDER) or ducted (OVER).;  
 (5) Static pressure obtainable at reduced air flow  
 Gross cooling capacities indicated. For net cooling capacities, subtract fan power input..

## TECHNICAL DATA - DATATECH+ ED DC

Unit size			23.1	27.1	35.2	36.2	45.2	44.2	66.3	82.3
<b>Cooling</b>										
Total cooling capacity	(1)	kW	21,5	27,0	36,1	34,3	45,4	44,5	66,8	81,4
Sensible cooling capacity	(1)	kW	20,5	25,0	35,0	34,1	43,0	42,6	63,2	76,1
SHR			0,95	0,93	0,97	0,99	0,95	0,96	0,95	0,93
EER	(1),(3)		3,66	3,59	3,74	3,88	3,65	3,77	3,82	3,70
Total cooling capacity	(2)	kW	23,3	25,6	40,4	40,4	52,7	52,7	88,2	96,7
Sensible cooling capacity	(2)	kW	21,1	23,5	36,9	36,9	47,5	47,5	74,1	82,2
SHR			0,91	0,92	0,91	0,91	0,90	0,90	0,84	0,85
<b>Compressors</b>										
Number		n°	1	1	2	2	2	2	3	3
Power input	(1)	kW	5,4	6,75	8,88	8,09	11,19	10,58	15,76	19,44
<b>Fans</b>										
Number		n°	1	1	2	2	2	2	3	3
Nominal air capacity		m³/h	6500	7650	11500	11500	13500	13500	20000	23000
Fan power input - UNDER version	(3)	kW	0,71	1,1	1,2	1,2	2,05	2,05	2,82	4
Fan power input - OVER version	(3)	kW	0,71	1,1	1,2	1,2	2,05	2,05	2,82	4
Maximum available static pressure - Downflow units	(6)	Pa	430	290	460	460	325	325	350	225
Maximum available static pressure - Upflow units	(6)	Pa	430	290	460	460	325	325	350	225
<b>Refrigerant connections (EDA units)</b>										
Gas supply		n°xmm	1 x 16	1 x 18	1 x 18	2 x 16	1 x 18	2 x 16	(1 x 16)+(1 x 18)	(1 x 16)+(1 x 18)
Liquid		n°xmm	1 x 16	1 x 16	1 x 18	2 x 16	1 x 18	2 x 16	(1 x 16)+(1 x 18)	(1 x 16)+(1 x 18)
<b>Plate condenser (EDW unit)</b>										
Number		n°	1	1	1	2	1	2	2	2
In/out connections		Pollici	G1"	G1 1/4"	G1 1/4"	G1"	G1 1/4"	G1"	G1 1/4"	G1 1/4"
Pressure drop		kPa	36	36	35	35	36	38	35	59
<b>Electric heating (CH-HH version)</b>										
Potential		kW	4,5	9	9	9	9	9	13,5	13,5
Operation stages		n°	1	2	2	2	2	2	3	3
<b>Humidifier (HH version)</b>										
Potential		kg/h	5	5	5	5	5	5	8	8
<b>Sound pressure levels (5)</b>										
Sound pressure levels - UNDER		dB(A)	53,9	57,9	59,9	59,9	60,6	60,6	63,6	64,6
Sound pressure levels - OVER		dB(A)	55,5	59,4	60,0	60,0	61,9	61,9	65,0	66,6
<b>Matching with remote condensers (EDA units) (5)</b>										
Number		n°	1	1	1	2	1	2	2	2
Model			NHNM 1245.2	NHNM 1245.3	NHNM 2335.3	NHNM 1145.4	NHNM 2245.2	NHNM 1245.2	NHNM 1245.2 + NHNM 2245.2	NHNM 1245.3 + NHNM 2245.3
Low noise model			NHLM 1245.3	NHLM 1250.5	NHLM 2245.2	NHLM 1245.2	NHLM 2245.3	NHLM 1245.3	NHLM 1245.3 + NHLM 2245.3	NHLM 1245.4 + NHLM 2245.3
Oversized model			NHNM 1245.3	NHNM 1245.4	NHNM 2245.2	NHNM 1245.2	NHNM 2245.3	NHNM 1245.3	NHNM 1245.4 + NHNM 2245.3	NHNM 1245.4 + NHNM 2245.4
Oversized low noise model			NHLM 1250.5	NHLM 2245.2	NHLM 2245.3	NHLM 1245.3	NHLM 2245.4	NHLM 1250.5	NHLM 1250.5 + NHLM 2245.2	NHLM 2245.2 + NHLM 2245.4
HT model			NHNM 2245.2	NHNM 2245.4	KA4M 2250.4	NHNM 2245.2	KA4M 2350.2	NHNM 2245.2	NHNM 2245.2 + KA4M 2250.4	NHNM 2245.3 + KA4M 2350.2
<b>Matching with remote drycoolers (EDW units) (5)</b>										
Number		n°	1	1	1	1	1	1	1	1
Model			DG5502CS	DG5502CS	DG5504BS	DG5504BS	DG5504CS	DG5504CS	DG5634CT	BDMS802DT
<b>Dimensions and weight of basic unit</b>										
Size of structure			S	S	M	M	M	M	L	L
Length		mm	1100	1100	1750	1750	1750	1750	2650	2650
Depth		mm	850	850	850	850	850	850	850	850
Height		mm	1990	1990	1990	1990	1990	1990	1990	1990
Operating weight UEDW HH		kg	411	418	644	643	680	662	1003	1035
Operating weight OEDW HH		kg	405	413	610	673	632	710	989	1035

(1) Air inlet 24°C 50%rh. 45°C saturated condensing temperature;

(2) Air inlet 24 °C 50% UR. water in/out 7/12 °C;

(3) 20Pa available pressure, ISO Coarse 75% (G4) filters;

(5) 2 m front of the unit, air distribution through raised floor (UNDER) or ducted (OVER);

(6) Static pressure obtainable at reduced air flow

Gross cooling capacities indicated. For net cooling capacities, subtract fan power input.

## TECHNICAL DATA - DATATECH+ EDW/FC

Unit size			23.1	27.1	35.2	36.2	45.2	44.2	66.3	82.3
<b>Cooling</b>										
Total cooling capacity	(1)	kW	21,2	26,7	35,7	33,9	44,8	44	66	80,5
Sensible cooling capacity	(1)	kW	20,5	25,0	34,9	34	42,8	42,5	63	75,9
SHR			0,97	0,94	0,98	1,00	0,96	0,97	0,95	0,94
EER	(1),(3)		3,59	3,51	3,50	3,61	3,33	3,45	3,51	3,40
<b>Free-Cooling</b>										
Total cooling capacity	(2)	kW	20,2	22,5	34,2	34,2	44,6	44,6	74,6	81,8
Sensible cooling capacity	(2)	kW	18,3	20,6	32,1	32,1	41,3	41,3	64,5	71,5
SHR			0,91	0,92	0,94	0,94	0,93	0,93	0,86	0,87
<b>Compressors</b>										
Number		n°	1	1	2	2	2	2	3	3
Power input	(1)	kW	5,2	6,5	9,0	8,2	11,4	10,7	16,0	19,7
<b>Fans</b>										
Nominal air capacity		n°	1	1	2	2	2	2	3	3
Nominal air capacity		m³/h	6.500	7.650	11.500	11.500	13.500	13.500	20.000	23.000
Fan power input - UNDER version	(3)	kW	0,7	1,1	1,2	1,2	2,0	2,0	2,8	4,0
Fan power input - OVER version	(3)	kW	0,7	1,1	1,2	1,2	2,0	2,0	2,8	4,0
Maximum available static pressure - Downflow units	(6)	Pa	430	290	516	516	373	373	393	285
Maximum available static pressure - Upflow units	(6)	Pa	430	290	516	516	373	373	393	285
<b>Plate condenser (EDW unit)</b>										
Number		n°	1	1	1	1	1	1	1	1
In/out connections		Pollici	G1"	G1 1/4"	G1 1/4"	G1"	G1 1/4"	G1"	G1 1/4"	G1 1/4"
Total pressure drop		kPa	59	75	61	61	79	81	81	86
<b>Electric heating (CH-HH version)</b>										
Potential		kW	4,5	9	9	9	9	9	13,5	13,5
Operation stages		n°	1	2	2	2	2	2	3	3
<b>Humidifier (HH version)</b>										
Potential		kg/h	5	5	5	5	5	5	8	8
<b>Sound pressure levels</b> (5)										
Sound pressure levels - UNDER		dB(A)	53,9	57,9	59,9	59,9	60,6	60,6	63,6	64,6
Sound pressure levels - OVER		dB(A)	55,5	59,4	60,0	60,0	61,9	61,9	65,0	66,6
<b>Matching with remote drycoolers (EDW units)</b> (5)										
Number		n°	1	1	1	1	1	1	1	1
Model			DGS502CS	DGS502CS	DGS504BS	DGS504BS	DGS504CS	DGS504CS	DGS634CT	BDM5802DT
<b>Dimensions and weight of basic unit</b>										
Cabinet size			S	S	M	M	M	M	L	L
Length		mm	1100	1100	1750	1750	1750	1750	2650	2650
Depth		mm	850	850	850	850	850	850	850	850
Height		mm	1990	1990	1990	1990	1990	1990	1990	1990
Operating weight U/O_EDW HH		kg	411	418	608	608	616	634	953	985

(1) Air inlet 24°C 50% rh. Condenser water inlet/outlet 35/40°C with 30% ethylene glycol;

(2) Freecooling coil water inlet/outlet temperature 7/12°C with 30% ethylene glycol;

(3) 20Pa available pressure, ISO Coarse 75% (G4) filters;

(5) 2 m front of the unit, air distribution through raised floor (UNDER) or ducted (OVER);

(6) Static pressure obtainable at reduced air flow

Gross cooling capacities indicated. For net cooling capacities, subtract fan power input.

## ELECTRICAL DATA DATATECH+ ED - DATATECH+ ED DC

Unit size			7.1m	7.1t	12.1	16.1	23.1	27.1	33.1	35.2
Compressor' s maximum power input		kW	2,9	2,9	5,8	9,2	11,8	14,2	18,6	16,6
Fan maximum power input		kW	0,44	0,44	1	1	2,3	2,3	2,3	4,6
Electrical heaters maximum power input		kW	3	3	4,5	4,5	4,5	9	9	9
Humidifier maximum power requirement		kW	2,3	2,3	2,3	2,3	6,0	6,0	6,0	6,0
Maximum compressor absorbed current	(1)	A	14,7	8,5	14	14	18	22,4	35	25,5
Maximum fan absorbed current	(1)	A	2,6	2,6	2,2	2,2	3,6	3,6	3,6	7,2
Electrical heaters maximum absorbed current	(1)	A	13,0	4,3	6,5	6,5	6,5	13,0	13,0	13,0
Humidifier maximum absorbed current	(1)	A	9,8	3,2	3,2	3,2	8,7	8,7	8,7	8,7
Power supply	(2)	V/ph/Hz	230/1~/50 ±5%				400/3~/50 ±5%			

Unit size			36.2	45.2	44.2	58.2	66.3	82.3	100.4	
Compressor' s maximum power input		kW	15,4	20,5	20	24,4	28,3	34,6	37,6	
Fan maximum power input		kW	4,6	4,6	4,6	4,6	6,9	6,9	6,9	
Electrical heaters maximum power input		kW	9	9	9	9	13,5	13,5	13,5	
Humidifier maximum power requirement		kW	6,0	6,0	6,0	6,0	6,0	6,0	6,0	
Maximum compressor absorbed current	(1)	A	25,8	32,8	33	43,4	48	64,4	65,2	
Maximum fan absorbed current	(1)	A	7,2	7,2	7,2	7,2	10,8	10,8	10,8	
Electrical heaters maximum absorbed current	(1)	A	13,0	13,0	13,0	13,0	19,5	19,5	19,5	
Humidifier maximum absorbed current	(1)	A	8,7	8,7	8,7	8,7	8,7	8,7	8,7	
Power supply	(2)	V/ph/Hz					400/3~/50 ±5%			

(1) Current consumption at the maximum allowable operating conditions. For the dimensioning of mains supply lines use appropriate safety coefficients;

(2) With remote condenser arrangement, mains supply MUST comprise neutral.;

## ELECTRICAL DATA - DATATECH+ EDW/FC

Unit size			23.1	27.1	35.2	36.2	45.2	44.2	66.3	82.3
Compressor' s maximum power input		kW	11,8	14,2	16,6	15,4	20,5	20,0	28,3	34,6
Fan maximum power input		kW	2,2	2,2	4,3	4,3	4,3	4,3	6,5	6,5
Electrical heaters maximum power input		kW	4,5	9	9	9	9	9	13,5	13,5
Humidifier maximum power requirement		kW	6,0	6,0	6,0	6,0	6,0	6,0	6,0	6,0
Maximum compressor absorbed current	(1)	A	18,0	22,4	25,5	25,8	32,8	33,0	48,0	64,4
Maximum fan absorbed current	(1)	A	3,3	3,3	6,6	6,6	6,6	6,6	9,9	9,9
Electrical heaters maximum absorbed current	(1)	A	6,5	13,0	13,0	13,0	13,0	13,0	19,5	19,5
Humidifier maximum absorbed current	(1)	A	8,7	8,7	8,7	8,7	8,7	8,7	8,7	8,7
Power supply	(2)	V/ph/Hz	400/3~/50 ±5%							

(1) Current consumption at the maximum allowable operating conditions. For the dimensioning of mains supply lines use appropriate safety coefficients.

### OPERATING LIMITS - DATATECH+ EDA (with remote condenser)

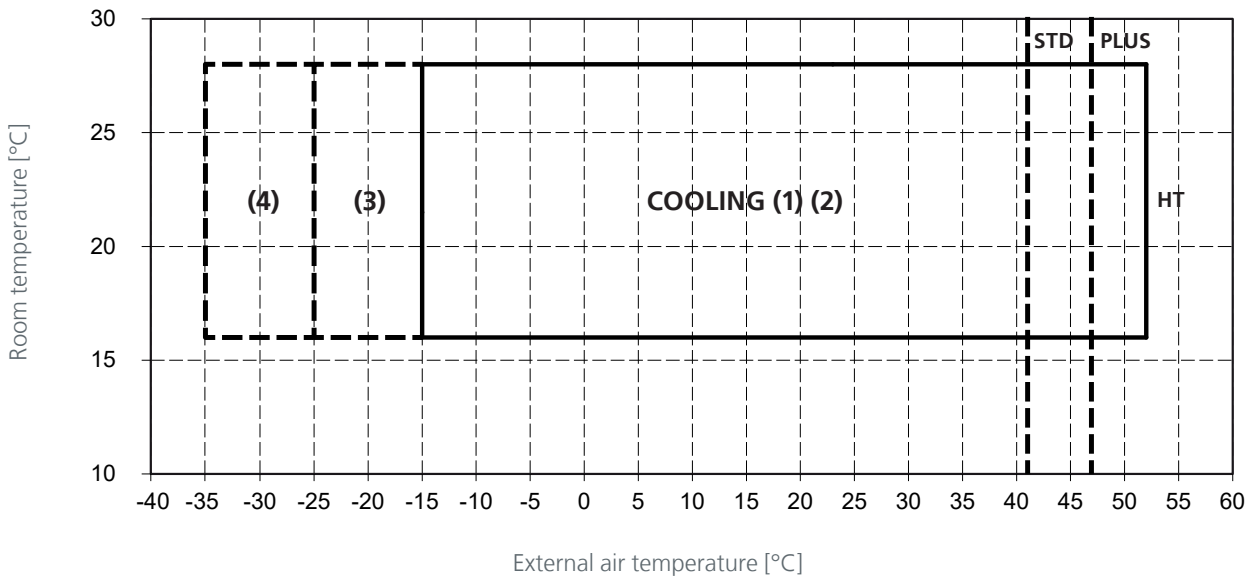

- (1) With Blue Box remote condenser and fan speed control
- (2) Limit is given at nominal conditions
- (3) With condensation control kit (LAK-Low Ambient Kit)
- (4) With oversized condensation control kit (LAM- Oversized Low Ambient Kit)
- (\*) Indicative temperature limit. Real value to be checked with Selection Software (varies by size, working conditions, length and path of pipes).

### OPERATING LIMITS - DATATECH+ EDA (without remote condenser)

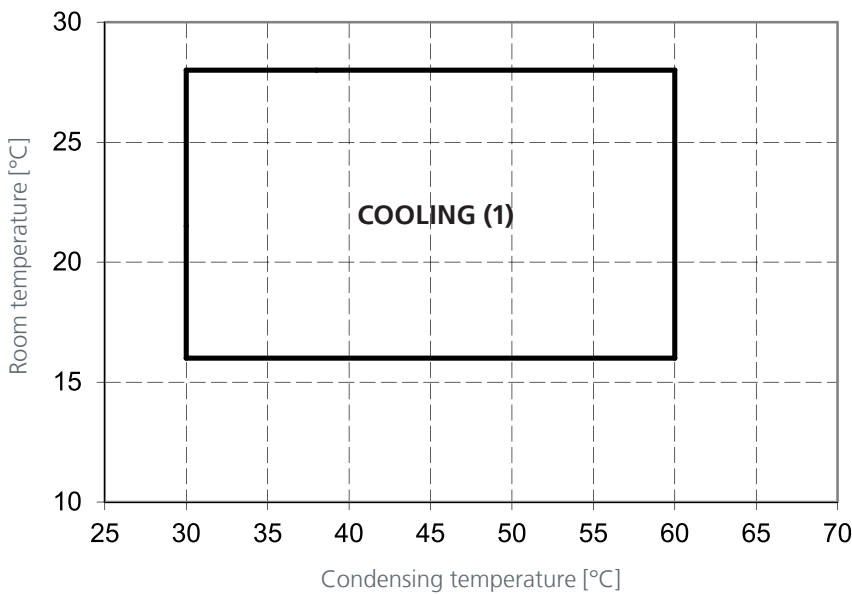

- (1) Limit is given at nominal conditions



## OPERATING LIMITS - DATATECH+ EDW

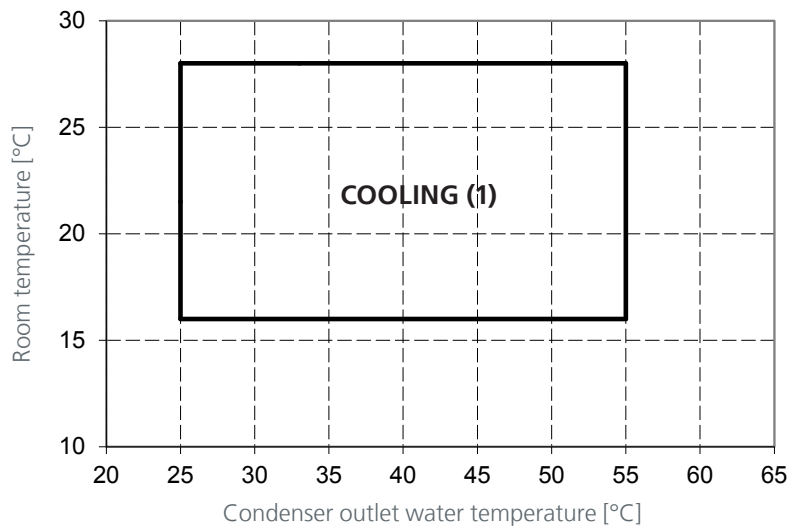

(1) Limit is given at nominal conditions

Dimensional drawing DATATECH+ UEDA/W XS INVERTER

A4D946-A

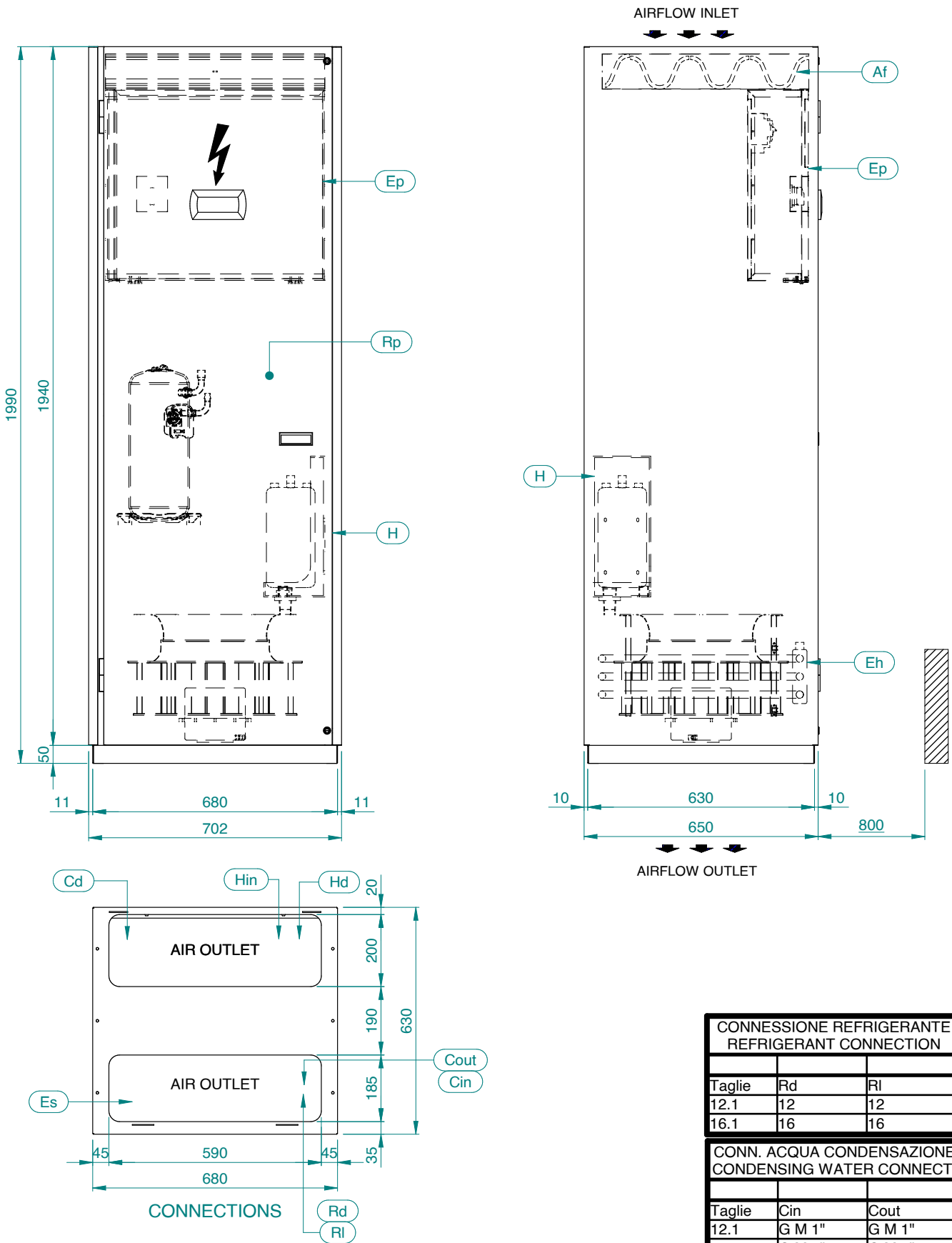

CONNESSIONE REFRIGERANTE REFRIGERANT CONNECTION			CONN. DC
Taglie	Rd	Ri	Gin/Gout
12.1	12	12	n.d.
16.1	16	16	n.d.

CONN. ACQUA CONDENSAZIONE CONDENSING WATER CONNECT.			CONN. DC
Taglie	Cin	Cout	Gin/Gout
12.1	G M 1"	G M 1"	n.d.
16.1	G M 1"	G M 1"	n.d.

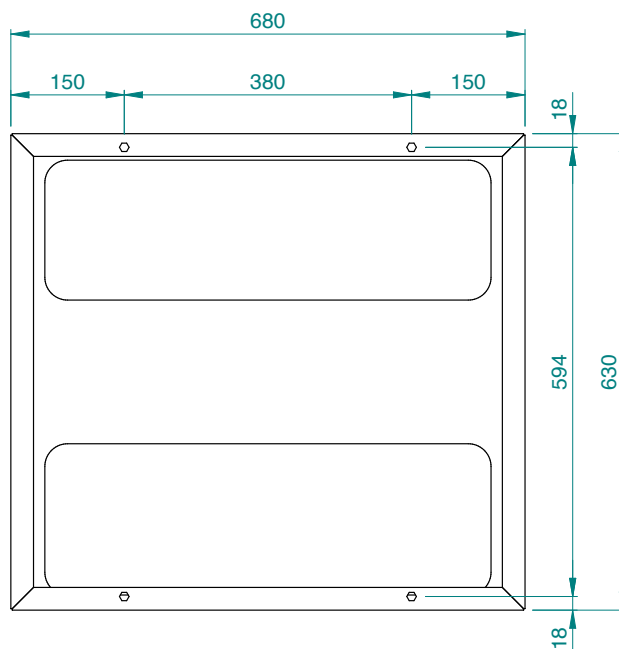

FOOT PRINT

WEIGHT UEDA/W INVERTER VERSION HH (Kg)	
MODEL	UEDA/W
12.1	232.6
16.1	254.8
VERSION CO, SUBTRACT Kg:	
	13.9
VERSION CH, SUBTRACT Kg:	
	9.9
VERSION EC FAN, SUBTRACT Kg:	
	19.4

Eh	RESISTENZE ELETTRICHE (SOLO CH, HH) ELECTRICAL HEATERS (CH, HH ONLY)	
Hin	INGR. ACQUA UMIDIFICATORE INLET HUMIDIFIER WATER	GAS M 3/4"
Hd	SCARICO ACQUA UMIDIFICATORE OUTLET HUMIDIFIER DRAIN	ODS 32
Rd	CONNESSIONI REFRIGERANTE (MANDATA) REFRIGERANT CONNECTIONS (DISCHARGE)	
Rl	CONNESSIONI REFRIGERANTE (LIQUIDO) REFRIGERANT CONNECTIONS (LIQUID)	
Cin	INGR. ACQUA CONDENSAZIONE CONDENSING WATER INLET	/
Cout	USCITA ACQUA CONDENSAZIONE CONDENSING WATER OUTLET	/

H	UMIDIFICATORE (SOLO HH) HUMIDIFIER (HH ONLY)	
Af	FILTRO ARIA AIR FILTER	
	SPAZI DI INSTALLAZIONE CLEARANCES	
Cd	SCARICO CONDENSA CONDENSATE DRAIN	ODS 3/4"
Ep	QUADRO ELETTRICO ELECTRICAL PANEL	
Es	INGRESSO ALIMENTAZIONE ELETTRICA ELECTRICAL SUPPLY INLET	
Rp	PANNELLO ASPORTABILE REMOVABLE PANEL	

Dimensional drawing DATATECH+ OEDA/W XS INVERTER

A4D947-A

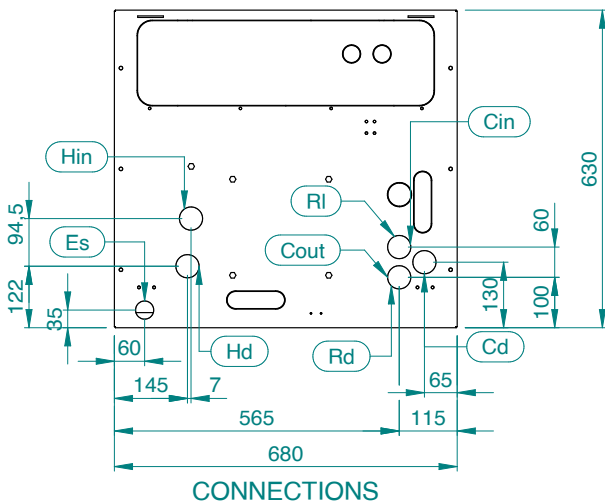
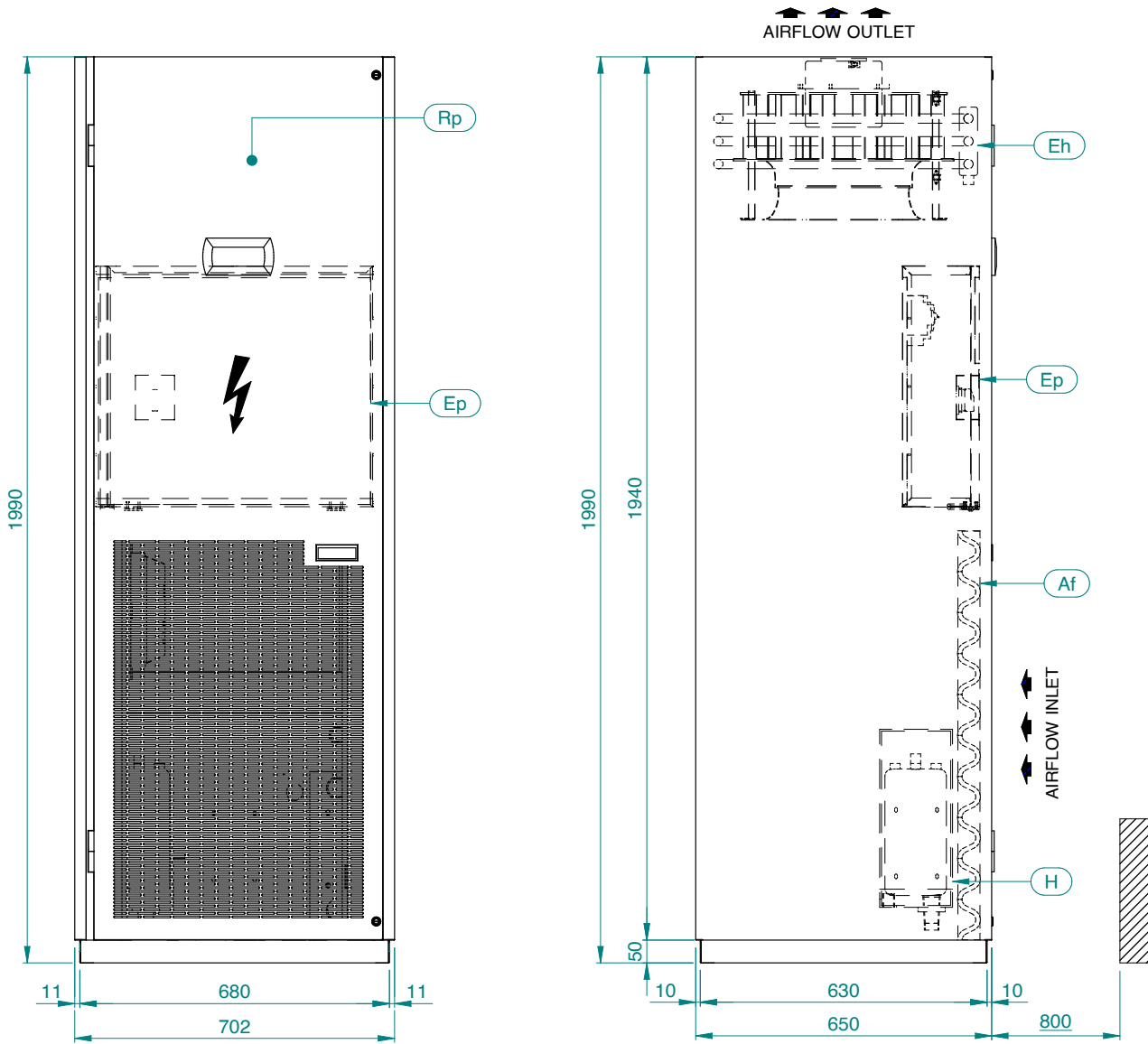

CONNESSIONE REFRIGERANTE REFRIGERANT CONNECTION			CONN. DC
Taglie	Rd	Ri	Gin/Gout
12.1	12	12	n.d.
16.1	16	16	n.d.

CONN. ACQUA CONDENSAZIONE CONDENSING WATER CONNECT.			CONN. DC
Taglie	Cin	Cout	Gin/Gout
12.1	G M 1"	G M 1"	n.d.
16.1	G M 1"	G M 1"	n.d.

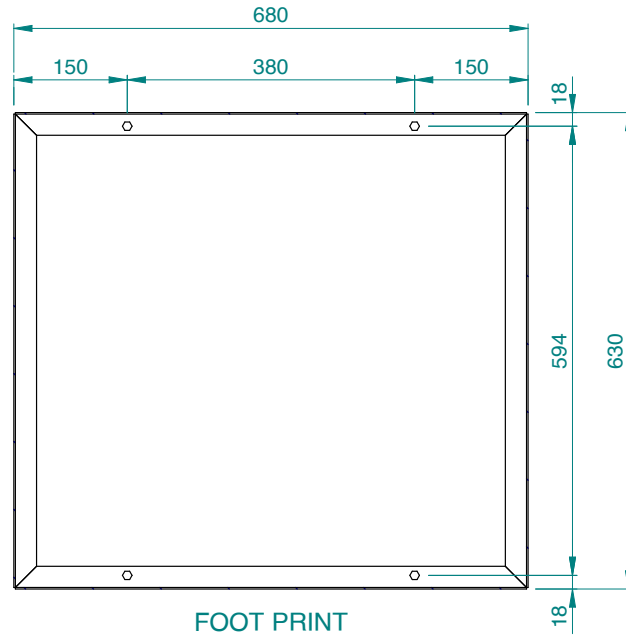

WEIGHT OEDA/W INVERTER VERSION HH (Kg)	
MODEL	OEDA/W
12.1	232.6
16.1	254.8
VERSION CO, SUBTRACT Kg:	13.9
VERSION CH, SUBTRACT Kg:	9.9
VERSION EC FAN, SUBTRACT Kg:	19.4

Eh	RESISTENZE ELETTRICHE (SOLO CH, HH) ELECTRICAL HEATERS (CH, HH ONLY)	
Hin	INGR. ACQUA UMIDIFICATORE INLET HUMIDIFIER WATER	GAS M 3/4"
Hd	SCARICO ACQUA UMIDIFICATORE OUTLET HUMIDIFIER DRAIN	ODS 32
Rd	CONNESSIONI REFRIGERANTE (MANDATA) REFRIGERANT CONNECTIONS (DISCHARGE)	
Rl	CONNESSIONI REFRIGERANTE (LIQUIDO) REFRIGERANT CONNECTIONS (LIQUID)	
Cin	INGR. ACQUA CONDENSAZIONE CONDENSING WATER INLET	/
Cout	USCITA ACQUA CONDENSAZIONE CONDENSING WATER OUTLET	/

H	UMIDIFICATORE (SOLO HH) HUMIDIFIER (HH ONLY)	
Af	FILTRO ARIA AIR FILTER	
	SPAZI DI INSTALLAZIONE CLEARANCES	
Cd	SCARICO CONDENSA CONDENSATE DRAIN	ODS 3/4"
Ep	QUADRO ELETTRICO ELECTRICAL PANEL	
Es	INGRESSO ALIMENTAZIONE ELETTRICA ELECTRICAL SUPPLY INLET	
Rp	PANNELLO ASPORTABILE REMOVABLE PANEL	

Dimensional drawing DATATECH+ UEDA/W S INVERTER

A4D948-B

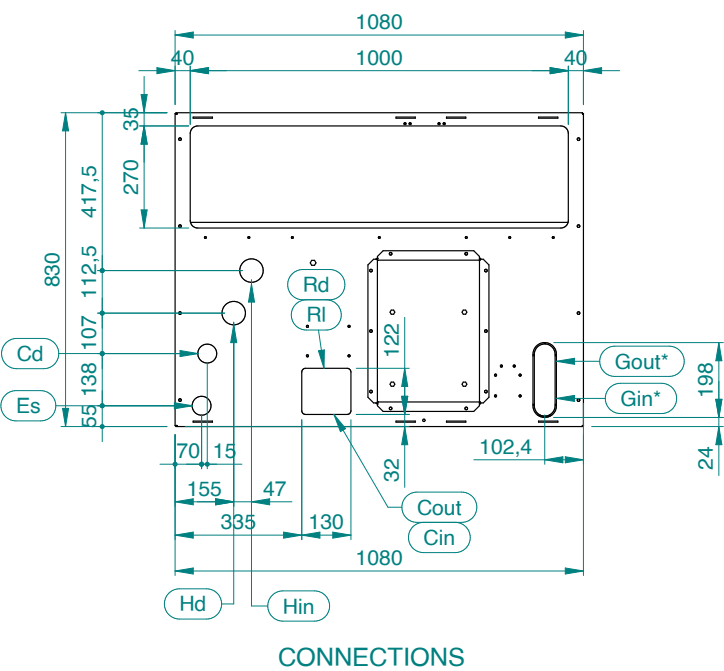
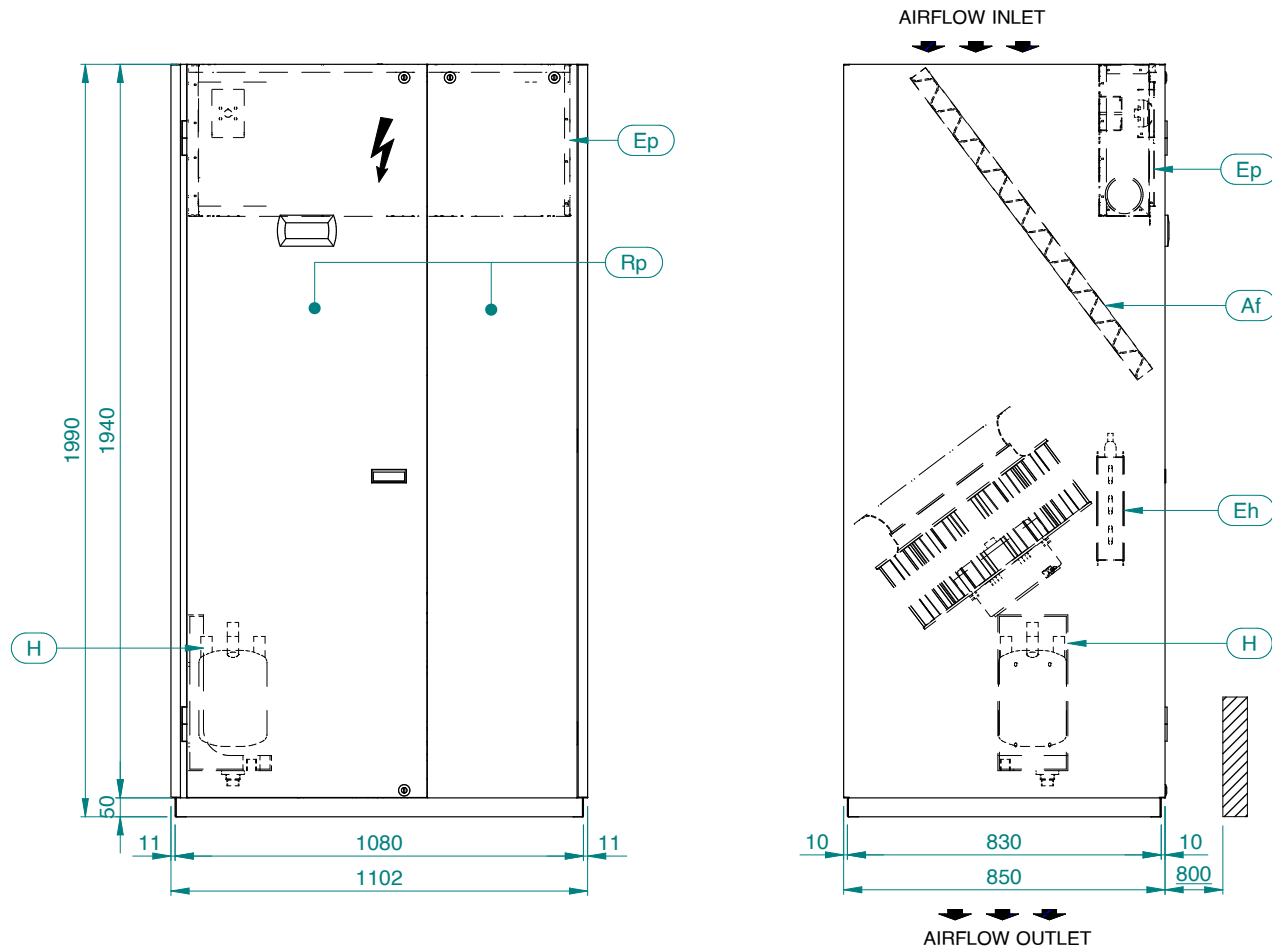

CONNESSIONE REFRIGERANTE REFRIGERANT CONNECTION			CONN. DC
Taglie	Rd	RI	Gin/Gout
23.1	16	16	1"
27.1	18	16	1"

CONN. ACQUA CONDENSAZIONE CONDENSING WATER CONNECT.			CONN. DC
Taglie	Cin	Cout	Gin/Gout
23.1	G M 1"	G M 1"	1"
27.1	G M 1"1/4	G M 1"1/4	1"

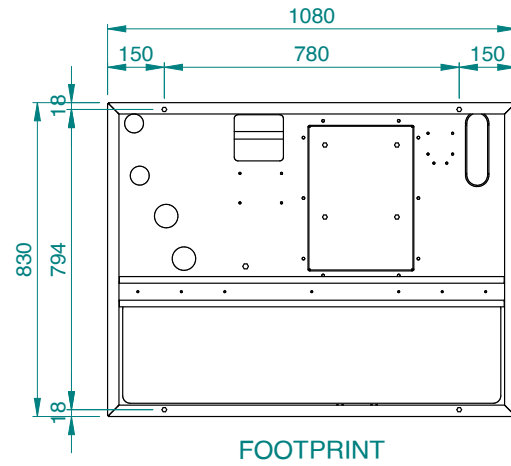
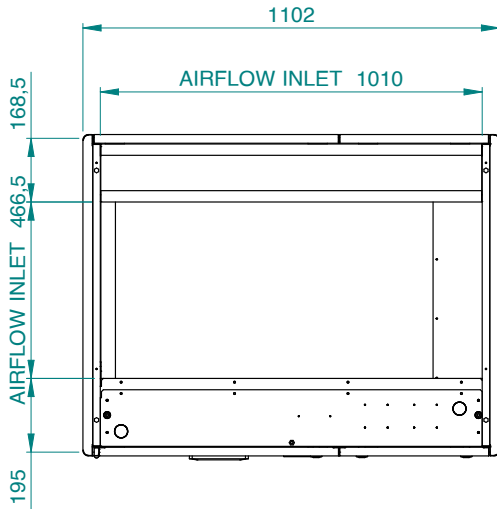

WEIGHT UEDA/W INVERTER VERSION HH (Kg)			
MODEL	UEDA	UEDW	UEDA/W DC
23.1	370.2	374.2	410.7
27.1	375.6	381.6	418.1
VERSION CO, SUBTRACT Kg:			17.9
VERSION CH, SUBTRACT Kg:			9.9

\* SOLO VERSIONE DC ONLY FOR DC VERSION

H UMIDIFICATORE (SOLO HH)  
HUMIDIFIER (HH ONLY)

Eh RESISTENZE ELETTRICHE (SOLO CH, HH)  
ELECTRICAL HEATERS (CH, HH ONLY)

Hin INGR. ACQUA UMIDIFICATORE  
INLET HUMIDIFIER WATER      GAS M 3/4"

Hd SCARICO ACQUA UMIDIFICATORE  
OUTLET HUMIDIFIER DRAIN      ODS 32

Rd CONNESSIONI REFRIGERANTE (MANDATA)  
REFRIGERANT CONNECTIONS (DISCHARGE)

Rl CONNESSIONI REFRIGERANTE (LIQUIDO)  
REFRIGERANT CONNECTIONS (LIQUID)

Cin INGR. ACQUA CONDENSAZIONE  
CONDENSING WATER INLET      /

Cout USCITA ACQUA CONDENSAZIONE  
CONDENSING WATER OUTLET      /

Af FILTRO ARIA  
AIR FILTER

SPAZI DI INSTALLAZIONE  
CLEARANCES

Cd SCARICO CONDENSA  
CONDENSATE DRAIN      ODS 3/4"

Gin INGR. ACQUA DA GRUPPO FRIGO  
INLET WATER FROM CHILLER      GAS 2" F

Gout USCITA ACQUA A GRUPPO FRIGO  
OUTLET WATER TO CHILLER      GAS 2" F

Ep QUADRO ELETTRICO  
ELECTRICAL PANEL

Es INGRESSO ALIMENTAZIONE ELETTRICA  
ELECTRICAL SUPPLY INLET

Rp PANNELLO ASPORTABILE  
REMOVABLE PANEL

Dimensional drawing DATATECH+ OEDA/W S INVERTER

A4D949-B

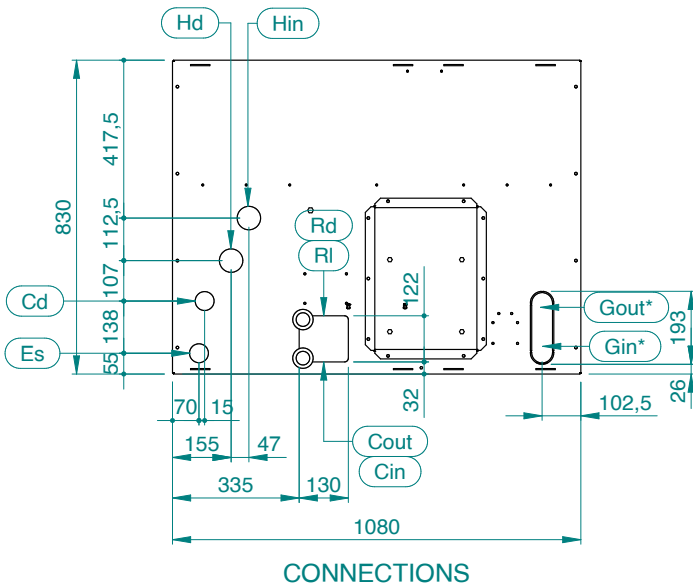
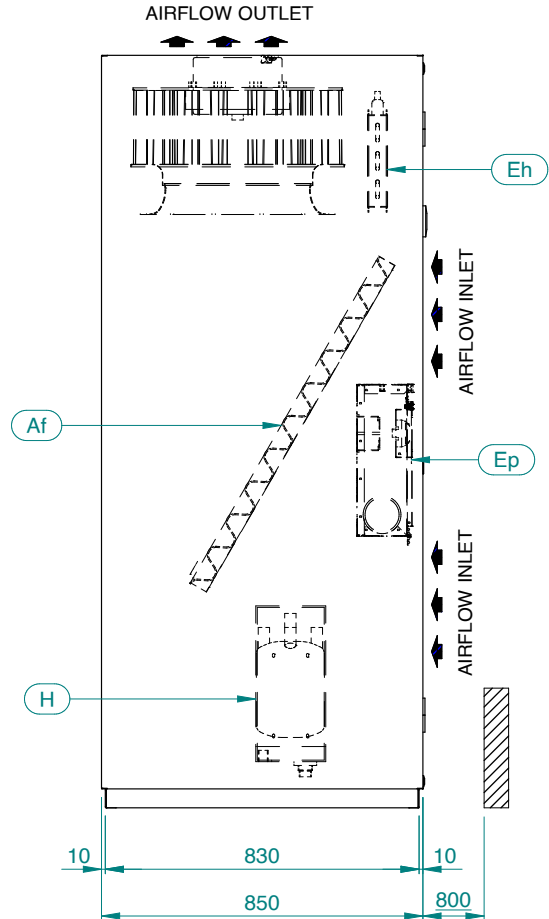
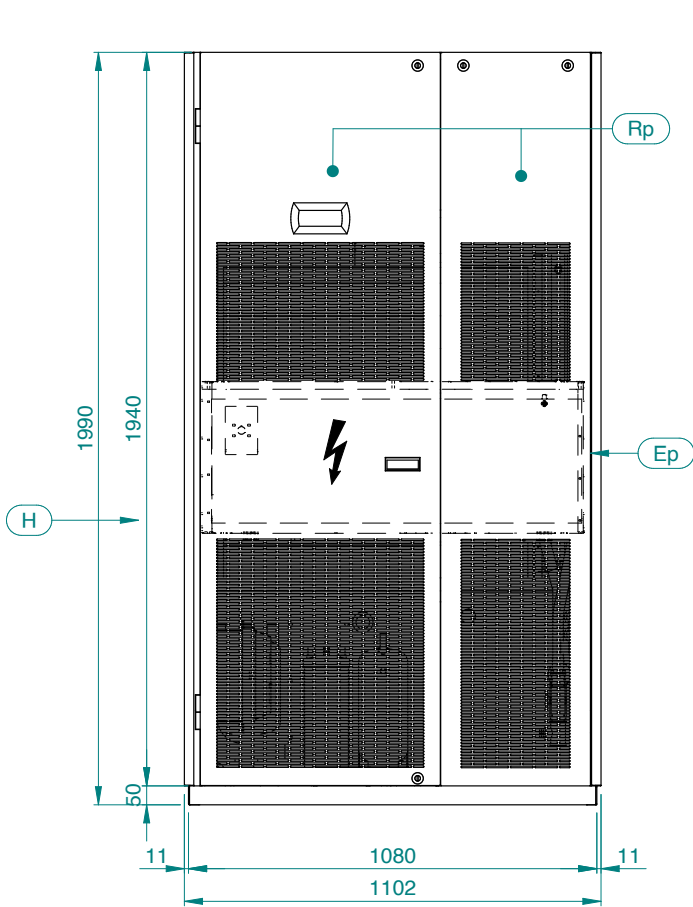

CONNECTIONS

CONNESSIONE REFRIGERANTE REFRIGERANT CONNECTION			CONN. DC
Taglie	Rd	Ri	Gin/Gout
23.1	16	16	1"
27.1	18	16	1"

CONN. ACQUA CONDENSAZIONE CONDENSING WATER CONNECT.			CONN. DC
Taglie	Cin	Cout	Gin/Gout
23.1	G M 1"	G M 1"	1"
27.1	G M 1"1/4	G M 1"1/4	1"



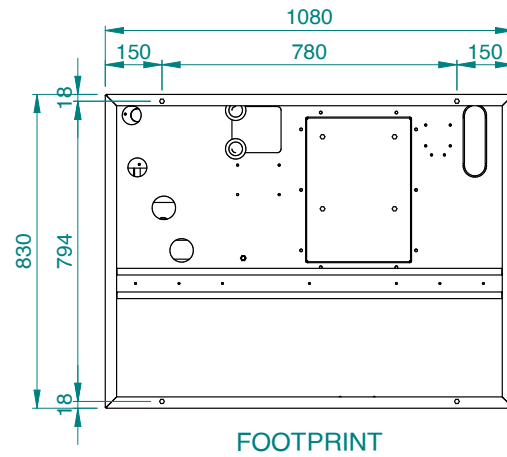
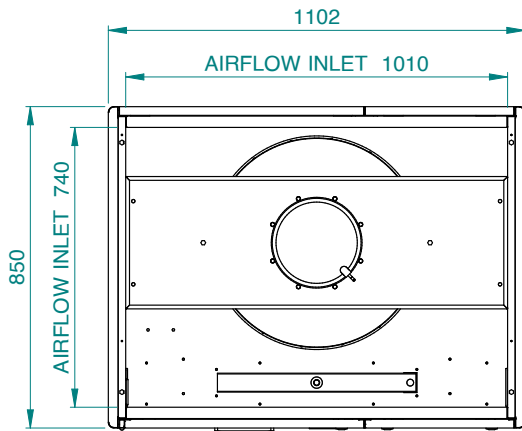

WEIGHT OEDA/W INVERTER VERSION HH (Kg)			
MODEL	OEDA	OEDW	OEDA/W DC
23.1	364.7	368.7	405.2
27.1	370.1	376.1	412.6
VERSION CO, SUBTRACT Kg:			17.9
VERSION CH, SUBTRACT Kg:			9.9

\* SOLO VERSIONE DC ONLY FOR DC VERSION

H	UMIDIFICATORE (SOLO HH) HUMIDIFIER (HH ONLY)	
Eh	RESISTENZE ELETTRICHE (SOLO CH, HH) ELECTRICAL HEATERS (CH, HH ONLY)	
Hin	INGR. ACQUA UMIDIFICATORE INLET HUMIDIFIER WATER	GAS M 3/4"
Hd	SCARICO ACQUA UMIDIFICATORE OUTLET HUMIDIFIER DRAIN	ODS 32
Rd	CONNESSIONI REFRIGERANTE (MANDATA) REFRIGERANT CONNECTIONS (DISCHARGE)	
Rl	CONNESSIONI REFRIGERANTE (LIQUIDO) REFRIGERANT CONNECTIONS (LIQUID)	
Cin	INGR. ACQUA CONDENSAZIONE CONDENSING WATER INLET	/
Cout	USCITA ACQUA CONDENSAZIONE CONDENSING WATER OUTLET	/

Af	FILTRO ARIA AIR FILTER	
	SPAZI DI INSTALLAZIONE CLEARANCES	
Cd	SCARICO CONDENSA CONDENSATE DRAIN	ODS 3/4"
Gin	INGR. ACQUA DA GRUPPO FRIGO INLET WATER FROM CHILLER	GAS 2" F
Gout	USCITA ACQUA A GRUPPO FRIGO OUTLET WATER TO CHILLER	GAS 2" F
Ep	QUADRO ELETTRICO ELECTRICAL PANEL	
Es	INGRESSO ALIMENTAZIONE ELETTRICA ELECTRICAL SUPPLY INLET	
Rp	PANNELLO ASPORTABILE REMOVABLE PANEL	

Dimensional drawing DATATECH+ UEDA/W M INVERTER

A4D950-A

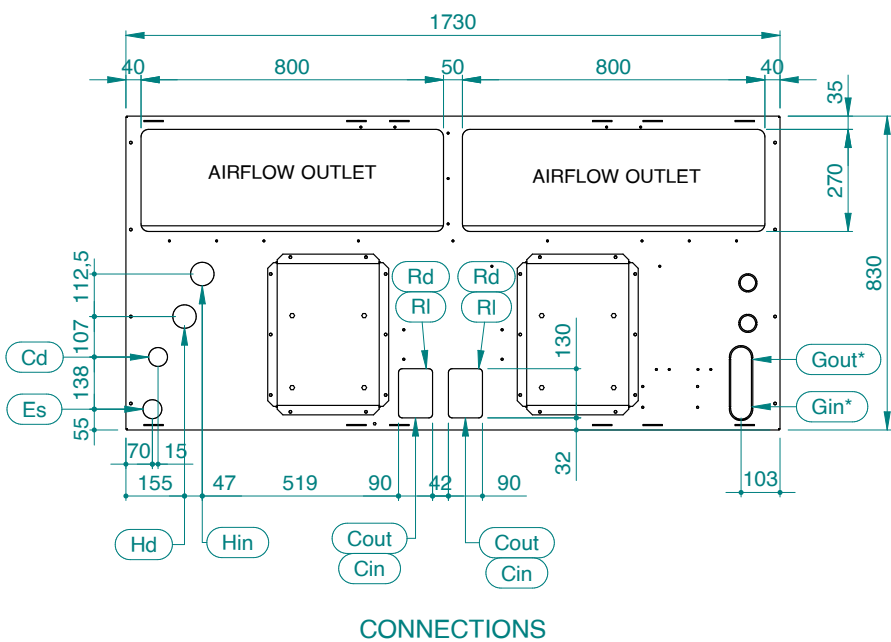
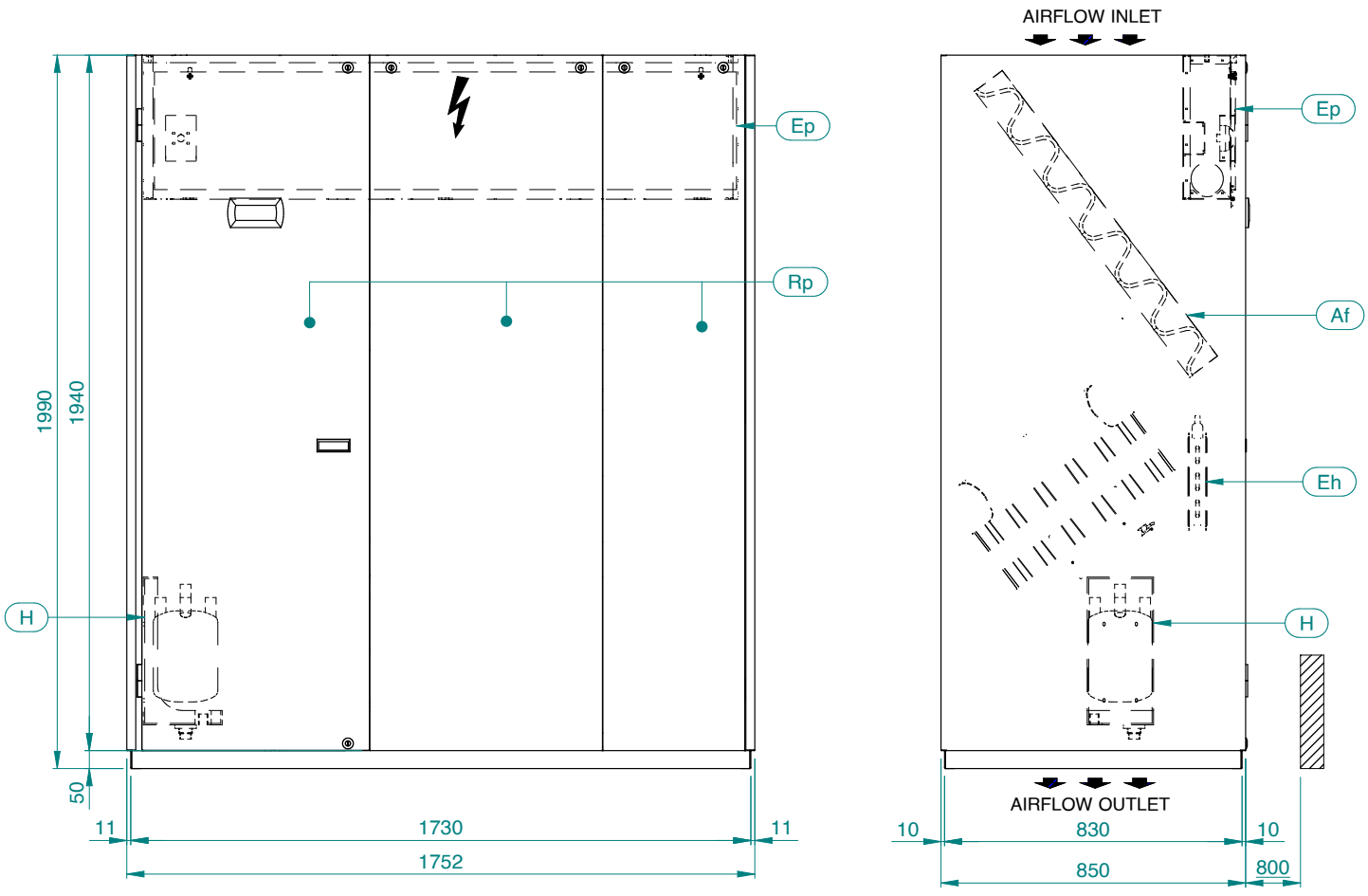

CONNECTIONS

CONNESSIONE REFRIGERANTE REFRIGERANT CONNECTION			CONN. DC
Taglie	Rd	Ri	Gin/Gout
35.1	18	18	1"1/4
CONN. ACQUA CONDENSAZIONE CONDENSING WATER CONNECT.			CONN. DC
Taglie	Cin	Cout	Gin/Gout
35.1	G M 1"1/4	G M 1"1/4	1"1/4

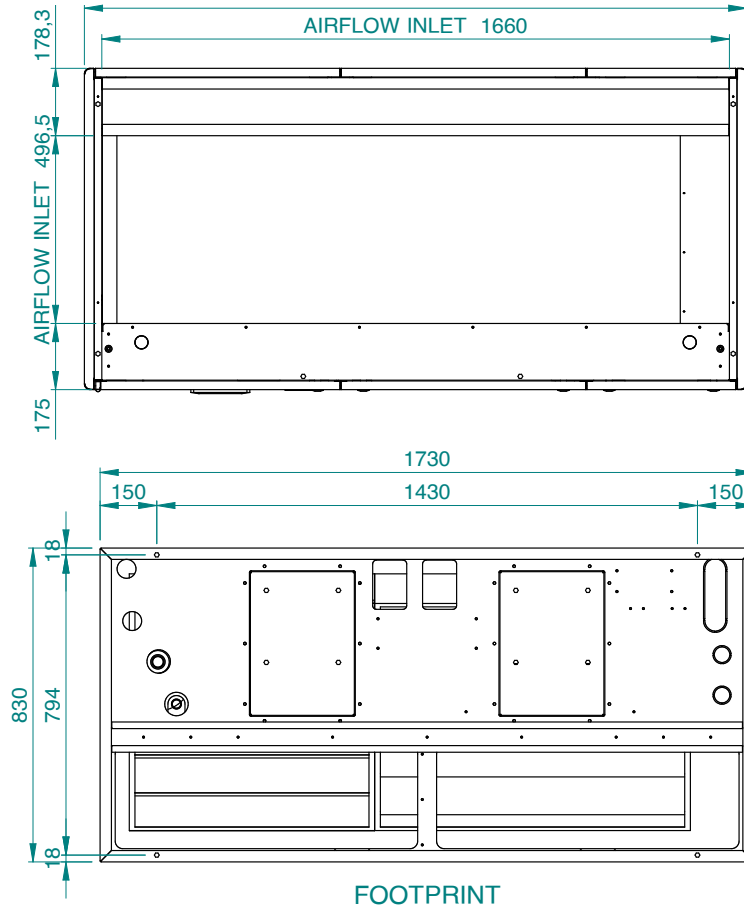

WEIGHT UNDER M INVERTER VERSION HH (Kg)		
MODEL	UEDW/A	UEDW/A DC
35.1	586.3	622.8
VERSION CO, SUBTRACT Kg:		17.9
VERSION CH, SUBTRACT Kg:		9.9
VERSION EC FAN, SUBTRACT Kg:		27.6

\* SOLO VERSIONE DC ONLY FOR DC VERSION

H	UMIDIFICATORE (SOLO HH) HUMIDIFIER (HH ONLY)	
Eh	RESISTENZE ELETTRICHE (SOLO CH, HH) ELECTRICAL HEATERS (CH, HH ONLY)	
Hin	INGR. ACQUA UMIDIFICATORE INLET HUMIDIFIER WATER	GAS M 3/4"
Hd	SCARICO ACQUA UMIDIFICATORE OUTLET HUMIDIFIER DRAIN	ODS 32
Rd	CONNESSIONI REFRIGERANTE (MANDATA) REFRIGERANT CONNECTIONS (DISCHARGE)	
Rl	CONNESSIONI REFRIGERANTE (LIQUIDO) REFRIGERANT CONNECTIONS (LIQUID)	
Cin	INGR. ACQUA CONDENSAZIONE CONDENSING WATER INLET	/
Cout	USCITA ACQUA CONDENSAZIONE CONDENSING WATER OUTLET	/

Af	FILTRO ARIA AIR FILTER	
	SPAZI DI INSTALLAZIONE CLEARANCES	
Cd	SCARICO CONDENSA CONDENSATE DRAIN	ODS 3/4"
Gin	INGR. ACQUA DA GRUPPO FRIGO INLET WATER FROM CHILLER	GAS 2" F
Gout	USCITA ACQUA A GRUPPO FRIGO OUTLET WATER TO CHILLER	GAS 2" F
Ep	QUADRO ELETTRICO ELECTRICAL PANEL	
Es	INGRESSO ALIMENTAZIONE ELETTRICA ELECTRICAL SUPPLY INLET	
Rp	PANNELLO ASPORTABILE REMOVABLE PANEL	

Dimensional drawing DATATECH+ OEDA/W M INVERTER

A4D951-A

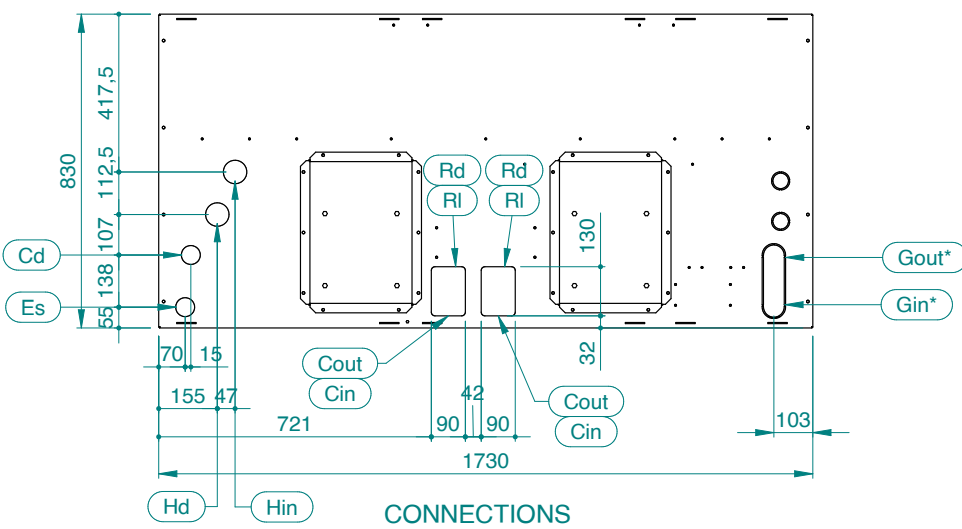
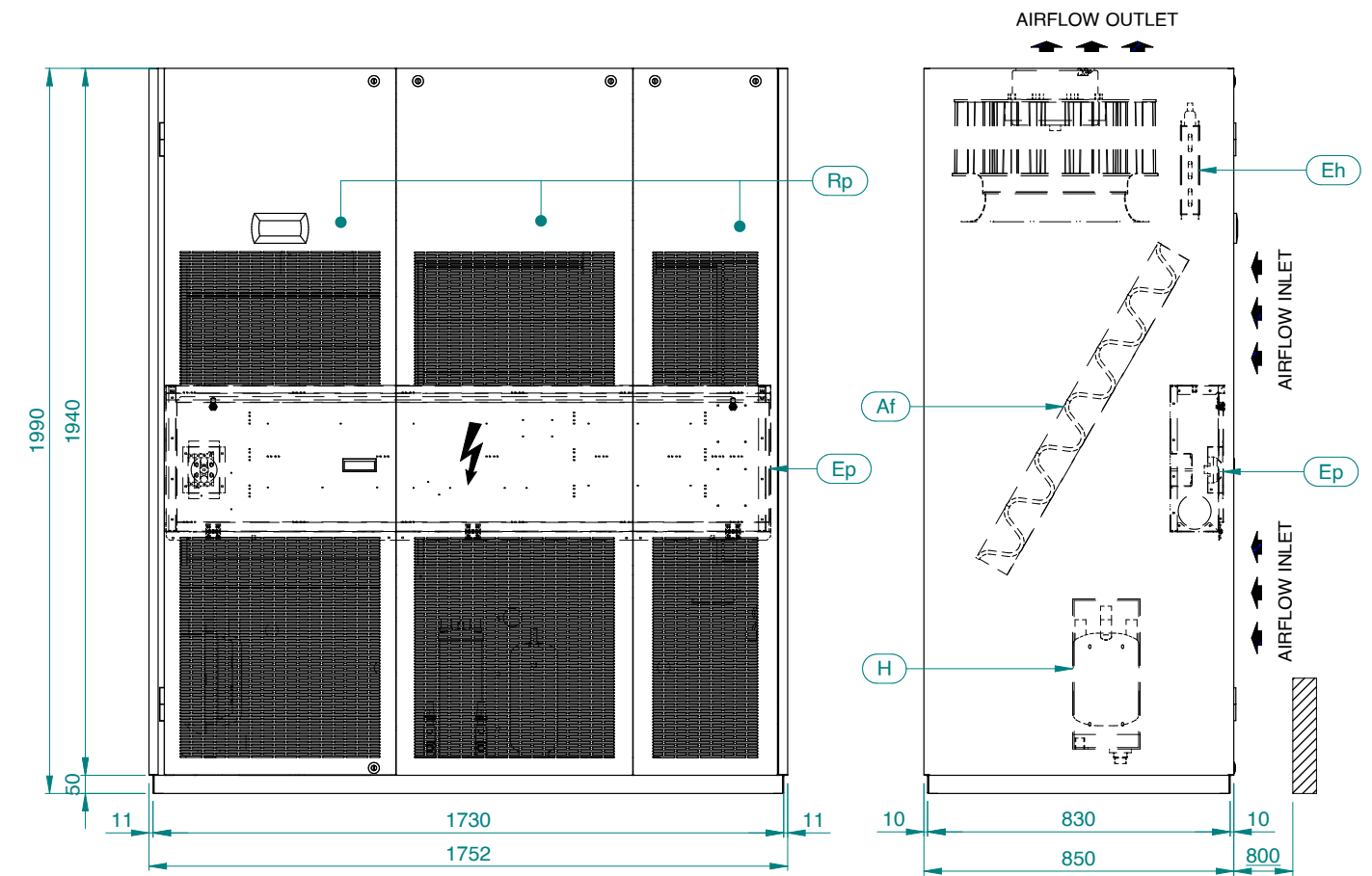

CONNESSIONE REFRIGERANTE REFRIGERANT CONNECTION			CONN. DC
Taglie	Rd	Ri	Gin/Gout
35.1	18	18	1"1/4
CONN. ACQUA CONDENSAZIONE CONDENSING WATER CONNECT.			CONN. DC
Taglie	Cin	Cout	Gin/Gout
35.1	G M 1"1/4	G M 1"1/4	1"1/4

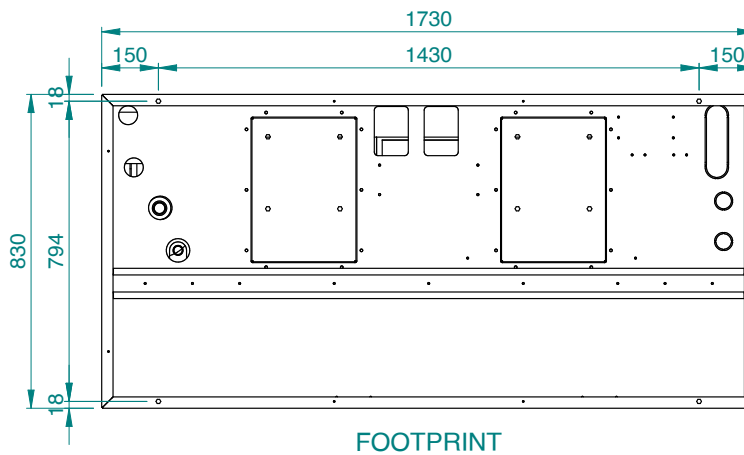
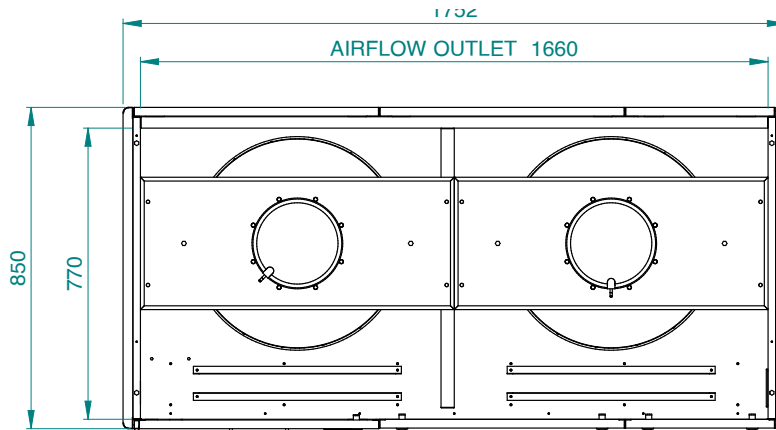

WEIGHT OVER M INVERTER VERSION HH (Kg)			
MODEL	OEDW/A		OEDW/A DC
35.1	556.3		592.8
VERSION CO, SUBTRACT Kg:			17.9
VERSION CH, SUBTRACT Kg:			9.9
VERSION EC FAN, SUBTRACT Kg:			27.6

\* SOLO VERSIONE DC ONLY FOR DC VERSION

H	UMIDIFICATORE (SOLO HH) HUMIDIFIER (HH ONLY)	
Eh	RESISTENZE ELETTRICHE (SOLO CH, HH) ELECTRICAL HEATERS (CH, HH ONLY)	
Hin	INGR. ACQUA UMIDIFICATORE INLET HUMIDIFIER WATER	GAS M 3/4"
Hd	SCARICO ACQUA UMIDIFICATORE OUTLET HUMIDIFIER DRAIN	ODS 32
Rd	CONNESSIONI REFRIGERANTE (MANDATA) REFRIGERANT CONNECTIONS (DISCHARGE)	
Rl	CONNESSIONI REFRIGERANTE (LIQUIDO) REFRIGERANT CONNECTIONS (LIQUID)	
Cin	INGR. ACQUA CONDENSAZIONE CONDENSING WATER INLET	/
Cout	USCITA ACQUA CONDENSAZIONE CONDENSING WATER OUTLET	/

Af	FILTRO ARIA AIR FILTER	
	SPAZI DI INSTALLAZIONE CLEARANCES	
Cd	SCARICO CONDENSA CONDENSATE DRAIN	ODS 3/4"
Gin	INGR. ACQUA DA GRUPPO FRIGO INLET WATER FROM CHILLER	GAS 2" F
Gout	USCITA ACQUA A GRUPPO FRIGO OUTLET WATER TO CHILLER	GAS 2" F
Ep	QUADRO ELETTRICO ELECTRICAL PANEL	
Es	INGRESSO ALIMENTAZIONE ELETTRICA ELECTRICAL SUPPLY INLET	
Rp	PANNELLO ASPORTABILE REMOVABLE PANEL	



10261000702 Datatech+\_10-2018

Blue Box Group S.r.l.  
via Valletta,5 - 30010 Cantarana di Cona (VE) - Italy  
tel. +39 0426 921111 - fax +39 0426 302222  
[www.blueboxgroup.it](http://www.blueboxgroup.it)

